

Phylogenetics trees

Tree types

Tree theory

Distance-based tree building

Parsimony

(, (, (,))))

Trees can be represented in "parenthesis notation".

Each set of parentheses represents a branch-point (bifurcation), the comma separates left and right lineages.

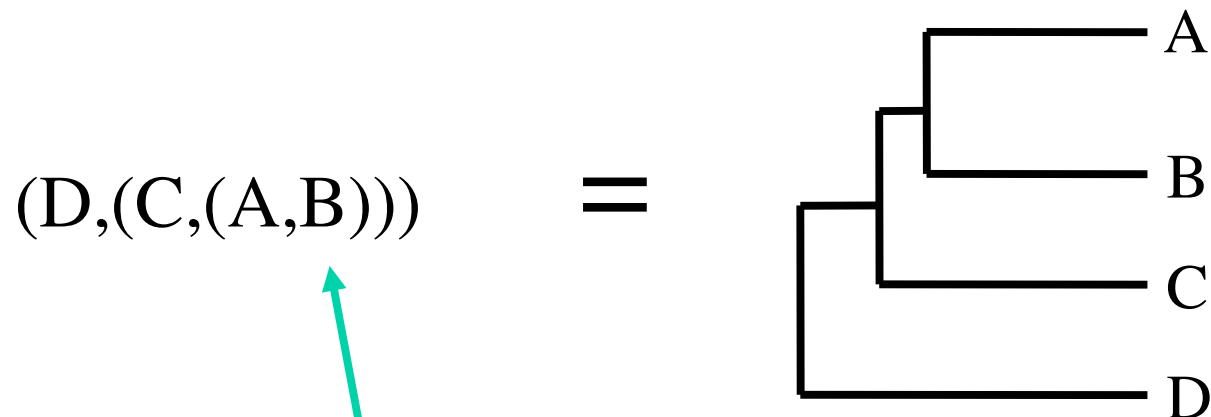

Parenthesis notation can contain sequence labels too.

Evolutionary time

Cladogram

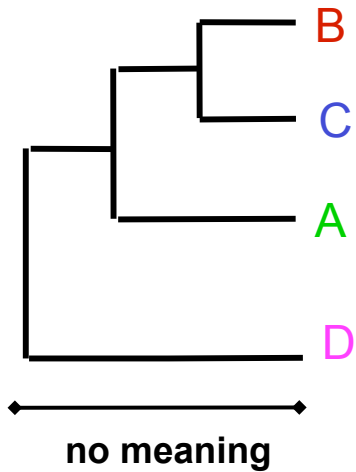

Phylogram

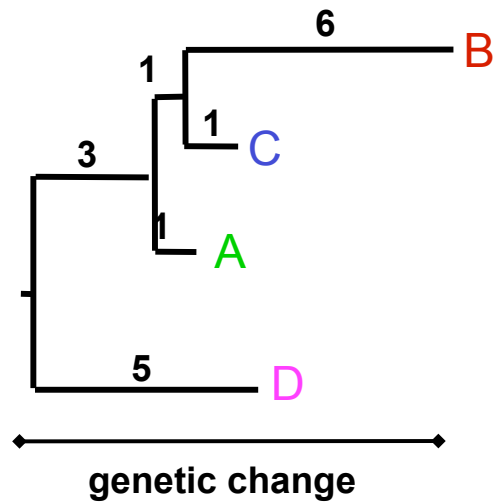

Ultrametric tree

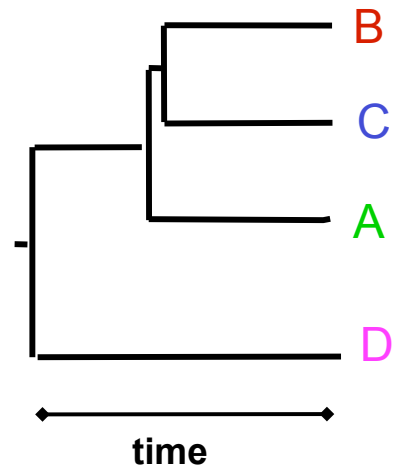

$(D:5,(A:1,(C:1,B:6):1):3)$

parenthesis notation can have both labels and distances.

Did the *Florida Dentist* infect his patients with HIV?

Phylogenetic tree of HIV sequences from the **DENTIST**, his Patients, & **Local HIV-infected People**:

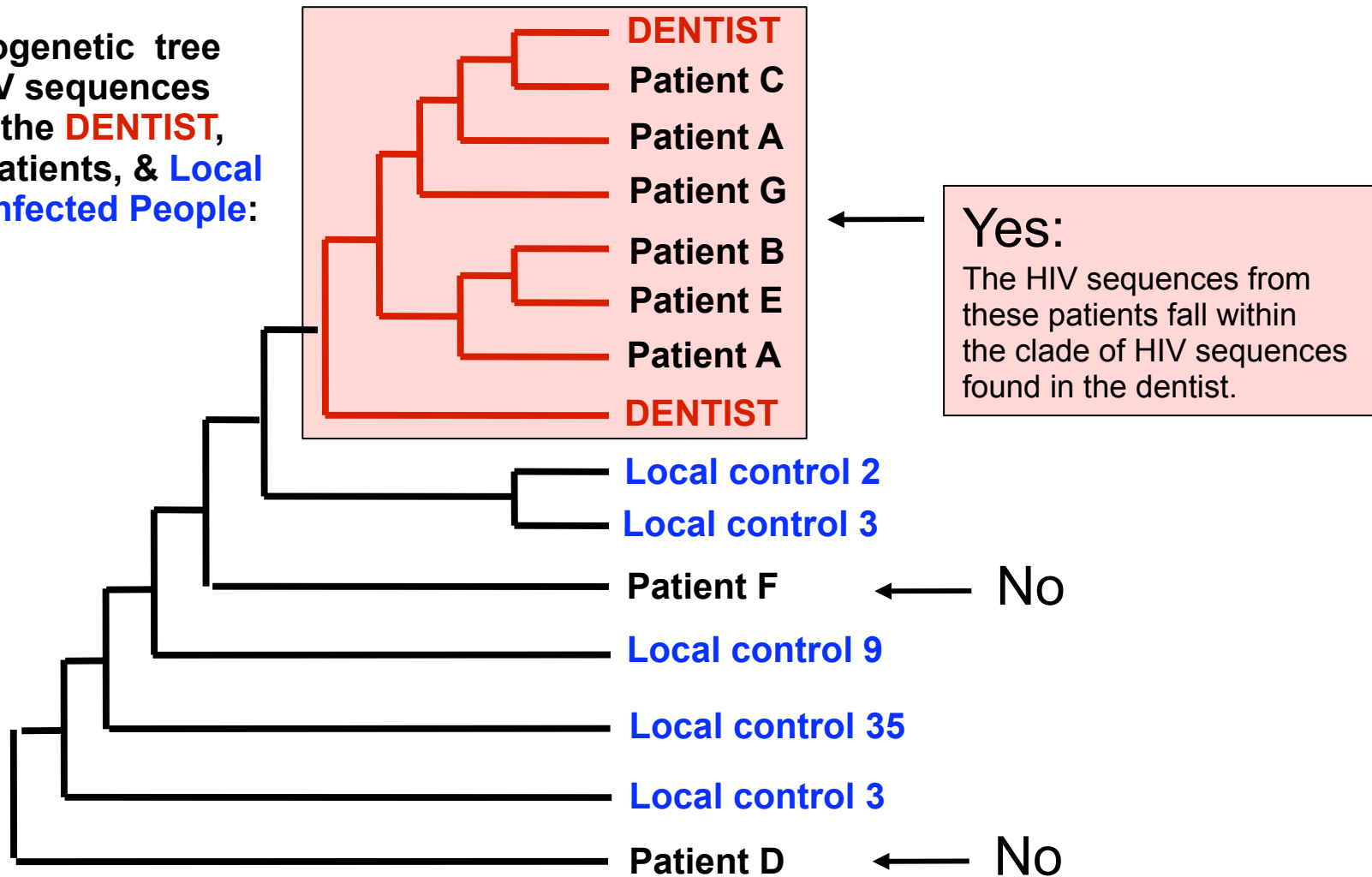

From Ou et al. (1992) and Page & Holmes (1998)

Character-based versus distance-based methods for tree building

Character-based methods: Use the aligned sequences directly during tree inference.

Taxa	Characters
Species A	ATGGCTATTCTTATAGTACG
Species B	ATCGCTAGTCTTATATTACA
Species C	TTCACTAGACCTGTGGTCCA
Species D	TTGACCAGACCTGTGGTCCG
Species E	TTGACCAGTTCTCTAGTTTCG

Distance-based methods: Transform the sequence data into pairwise distances, and then use the matrix during tree building, ignoring characters.

	A	B	C	D	E
Species A	----	0.20	0.50	0.45	0.40
Species B	0.23	----	0.40	0.55	0.50
Species C	0.87	0.59	----	0.15	0.40
Species D	0.73	1.12	0.17	----	0.25
Species E	0.59	0.89	0.61	0.31	----

Calculating distances

Uncorrected distance: count the changes, divide by the length.

Species A	A	T	G	G	C	T	A	T	T	C	T	T	A	T	A	G	T	A	C	G
Species B	A	T	C	G	C	T	A	G	T	C	T	T	A	T	A	T	T	A	C	A
Species C	T	T	C	A	C	T	A	G	A	C	C	T	G	T	G	G	T	C	C	A
Species D	T	T	G	A	C	C	A	G	A	C	C	T	G	T	G	G	T	C	C	G
Species E	T	T	G	A	C	C	A	G	T	T	C	T	C	T	A	G	T	T	C	G

$$D(A,B) = 4/20$$

Top: uncorrected p-distance, Bottom: Jukes-Cantor distance

	A	B	C	D	E
Species A	----	0.20	0.50	0.45	0.40
Species B	0.23	----	0.40	0.55	0.50
Species C	0.87	0.59	----	0.15	0.40
Species D	0.73	1.12	0.17	----	0.25
Species E	0.59	0.89	0.61	0.31	----

Jukes-Cantor correction:

$$K(A,B) = -3/4 \ln [1 - 4/3 D(A,B)]$$

Homoplasy

Independent evolution of the same character.

- (1) Convergent events (in either related or unrelated entities),
- (2) Parallel events (in related entities)
- (3) Reversals (in related entities)

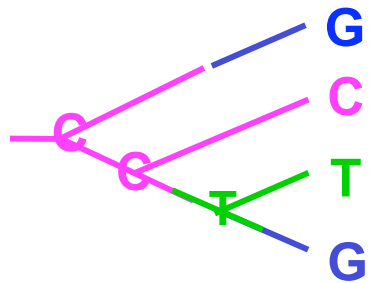

(1)

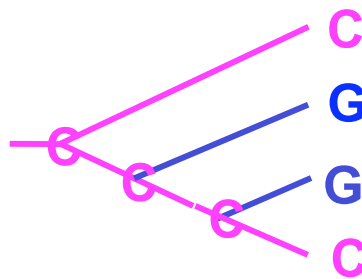

(2)

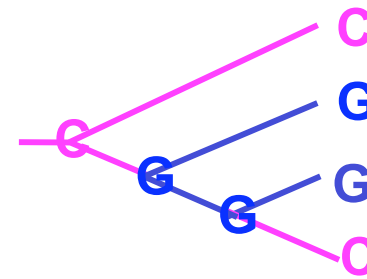

(3)

The **Jukes-Kantor correction** assumes homoplasy occurs at the rate predicted by random mutations.

Neighbor joining: a distance-based method

Choose the closest neighbors. Add a node between them.
Choose the next closest, and so on.

	A	B	C	D	E
Species A	----	0.20	0.50	0.45	0.40
Species B	0.23	----	0.40	0.55	0.50
Species C	0.87	0.59	----	0.15	0.40
Species D	0.73	1.12	0.17	----	0.25
Species E	0.59	0.89	0.61	0.31	----

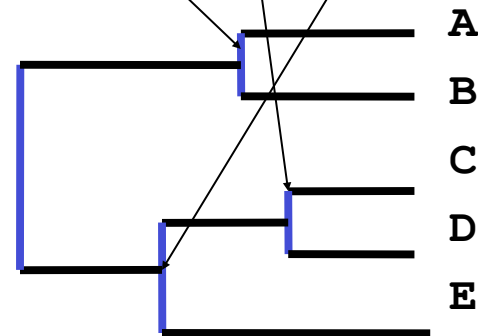

Neighbor joining: phylogram

Finally, **adjust the branch lengths** to fit the distances, if possible!

	A	B	C	D	E
Species A	----	0.20	0.50	0.45	0.40
Species B	0.23	----	0.40	0.55	0.50
Species C	0.87	0.59	----	0.15	0.40
Species D	0.73	1.12	0.17	----	0.25
Species E	0.59	0.89	0.61	0.31	----

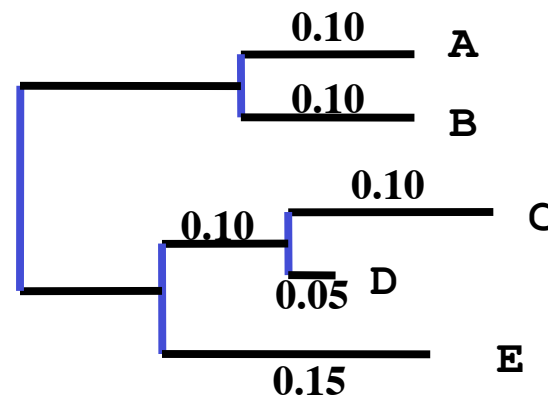

In class: create a rooted phylogram with
4 taxa

A	TTG ACC AG ACCT TGT GGT CCG
B	TTG AAC AG ACCT TGC GGT CGG
C	TAG AAA AG ACCT TGT CGT AGG
D	GTG CAA AGT CCT TGT GT ATCG

Directions:

- Make a distance matrix
- Use Neighbor-joining to make a tree.
- Adjust branch lengths using Fitch-Margoliash.
- Choose the root using the Midpoint method.

Which method do I use?

Sequence similarity

strong

weak

very weak

Method to use

parsimony

distance

maximum likelihood



Geneious exercise

- Search NCBI-->Protein for any gene (example: mitochondrial peptidase)
- Run a **blastp** search on that gene.
- Select 8 sequences with e-values between 0.1 and 0.00001
- Align the sequences using Geneious Align. Rename them A,B,C,D,E,F,G and H for simplicity.
- Trim the alignment.
- Extract a 20 aa block. Save it separately.
- Make a UPGMA tree using distances. Draw the cladogram with taxa.
- Repeat with a different 20 aa block, until you have 5 trees.

- Compare the five trees. Choose a tree as the “consensus” tree.
- For each node in the consensus tree, count how many trees have the equivalent branch point, or node (identical sub-clade content).
- Write this number (1-5) at the node position on the consensus tree.

If you did this exercise 100 times and counted the times you get a certain branch point, then you have computed a "*bootstrapping*" value for that branch point.

Fitch-Margoliash algorithm for calculating the branch lengths

1. Find the most closely-related pair of sequences, **A** and **B**
2. Calculate the average distance from **A** to all other sequences.  then from **B** to all other sequences. 
3. Adjust the position of the common ancestor node for **A** and **B** so that the difference between the averages is equal to the difference between the **A** and **B** branch lengths, while the sum of the branch lengths is $D(A,B)$.

NOTE: the difference between the averages may be greater than $D(A,B)$, making step 3 *impossible*.

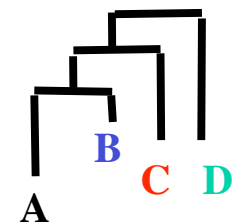
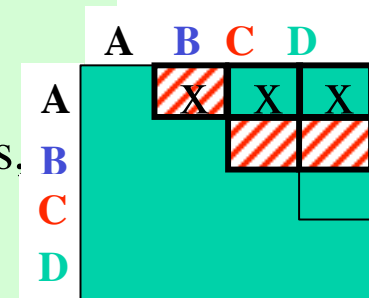
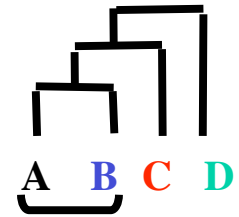

Distance metrics

METRIC DISTANCES between any two or three taxa (a, b, and c) have the following properties:

Property 1: $d(a, b) \geq 0$

Property 2: $d(a, b) = d(b, a)$

Property 3: $d(a, b) = 0$ if and only if $a = b$

Property 4: $d(a, c) \leq d(a, b) + d(b, c)$

Non-negativity

Symmetry

Distinctness

Triangle inequality

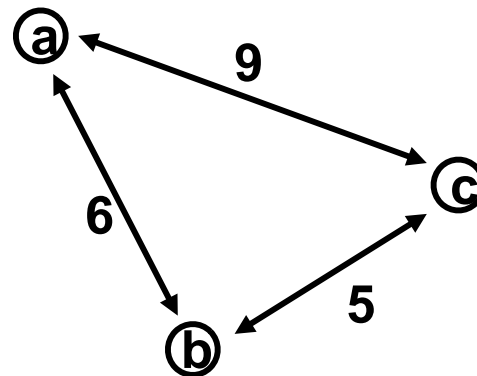

ULTRAMETRIC DISTANCES

must satisfy the previous four conditions, plus:

Property 5 *The distances from any branch point to the taxa in the clade defined by that branch point are equal.*

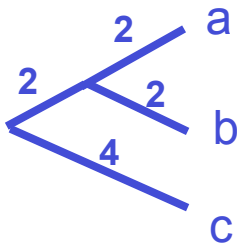

If distances are *ultrametric*, then the sequences are evolving in a perfectly clock-like manner. So any two sequences always have the same distance to their common ancestor.

Additivity

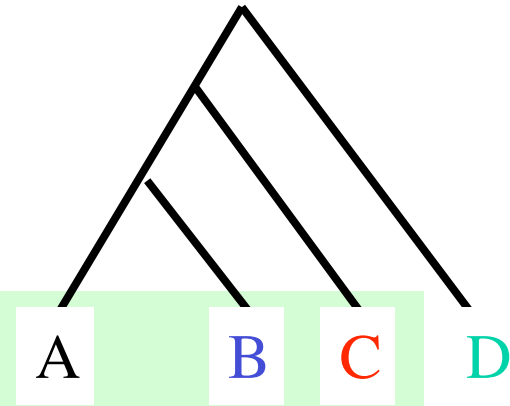

ADDITIVE DISTANCES:

Property 6: Example: if (a,b) are nearest neighbors,

$$d(a, b) + d(c, d) \leq \text{maximum} [d(a, c) + d(b, d), d(a, d) + d(b, c)]$$

For distances to fit into an evolutionary tree, they must be additive. Estimated distances often fall short of these criteria, and thus can fail to produce correct evolutionary trees.

A lineage that goes *backwards* in time violates additivity.

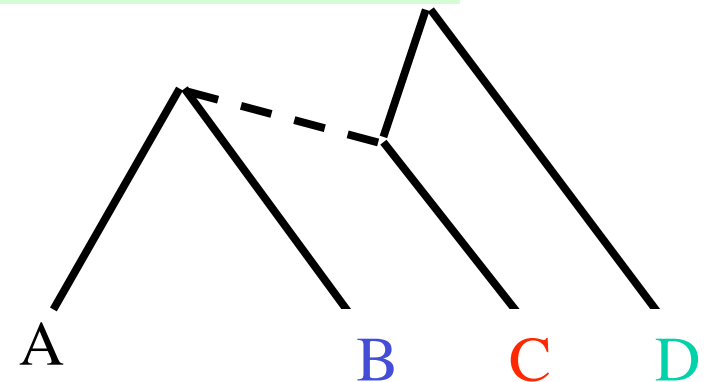

What's wrong with this tree?

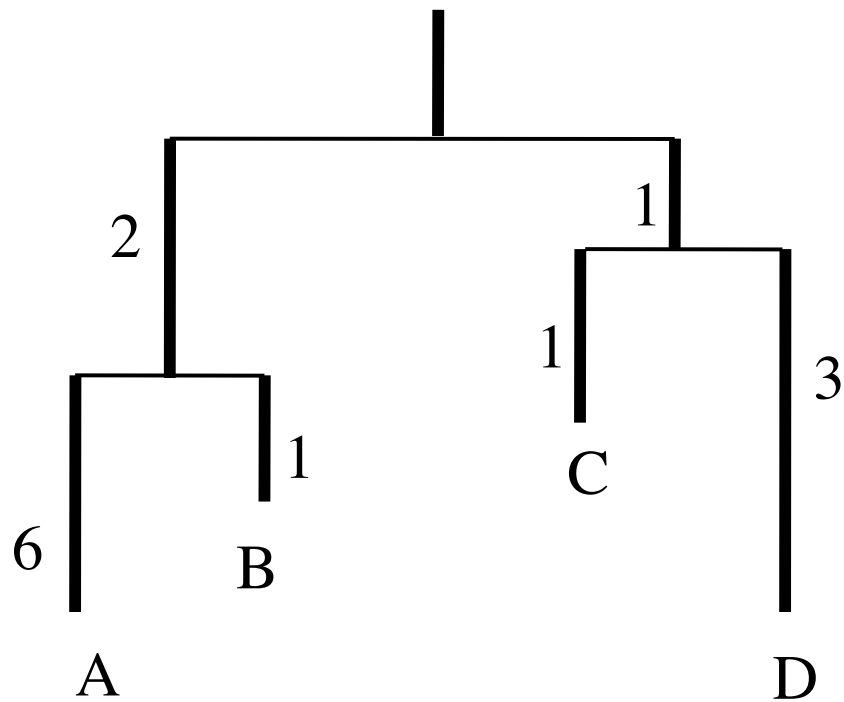

What's wrong with these distances?

	A	B	C	D
A		3	5	7
B			1	4
C				9
D				

Maximum parsimony -- it's “character-building”

Optimality criterion: The ‘most-parsimonious’ tree is the one that requires the fewest number of evolutionary events (e.g., nucleotide substitutions, amino acid replacements) to explain the sequences.

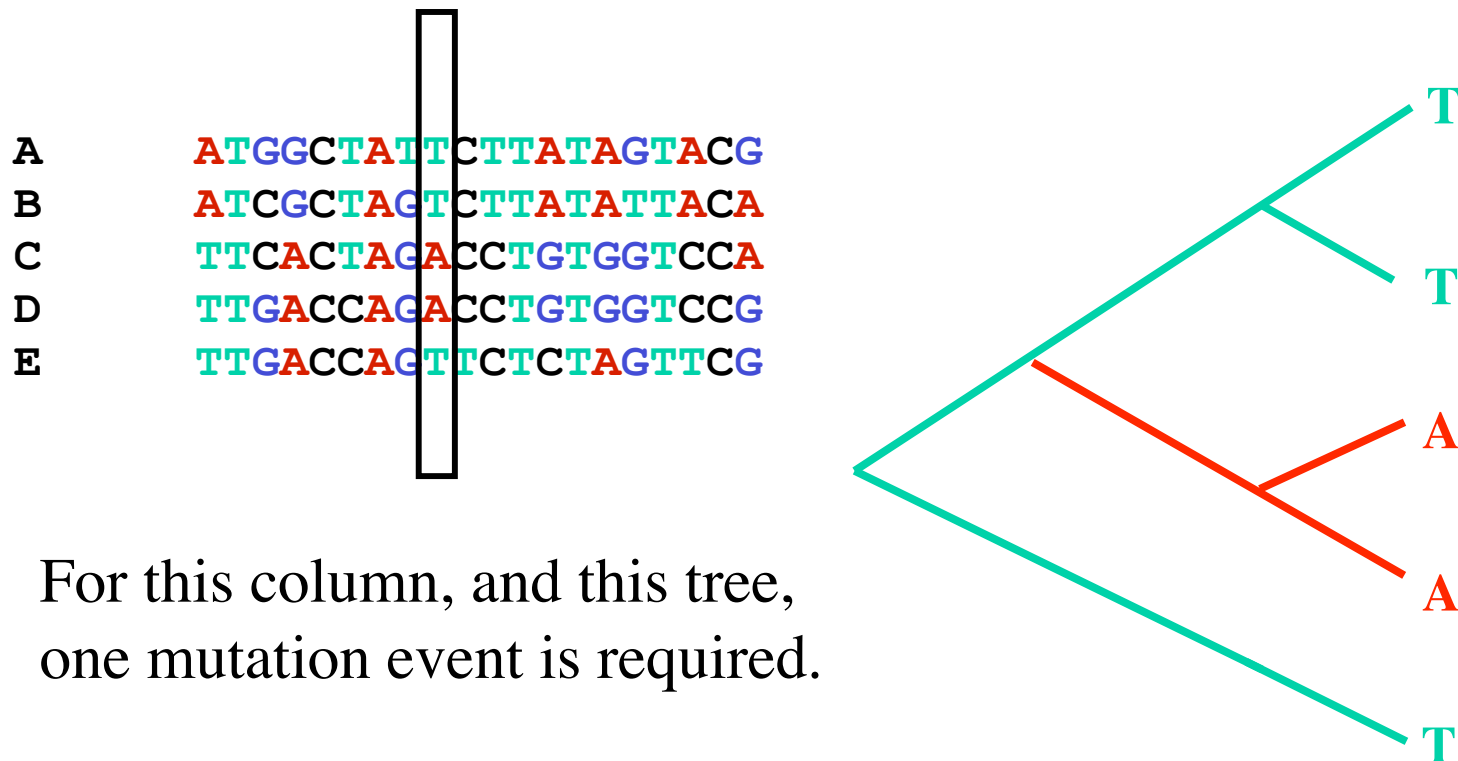

character-based tree-building

For this other column, the same tree requires **two** mutation events. A different tree would require only one.

A	ATGGCTATTCTTATAGTACG
B	ATCGCTAGTCTTATATTACA
C	TTCACTAGACCCTGTGGTCCA
D	TTGAOCAGACCCTGTGGTCCG
E	TTGAOCAGTICTCTAGTTTCG

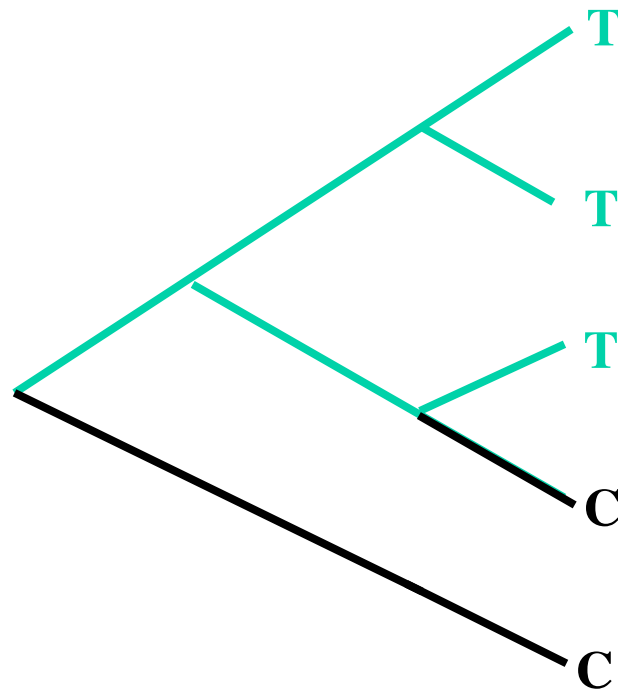

Max Parsimony: Trying all trees

. . . . | 0 | 0
A **A**T**G**G**C**T**A**T**T**C**T**T**A**T**A**G**T**A**C**G
B **A**T**C**G**C**T**A**G**T**C**T**T**A**T**A**T**T**A**C**A
C **T**T**C**A**C**T**A**G**A**C**C**T**G**T**G**G**T**C**C**A
D **T**T**G**A**C**C**A**G**A**C**C**T**G**T**G**G**T**C**C**G
E **T**T**G**A**C**C**A**G**T**T**C**T**C**T**A**G**T**T**C**G



1	0																
1	0																
2	0																
1	0																

TOTALS
